

# Update on VFB Projects in China

Lei Xia, ASIACHEM



# 中国钒液流电池项目发展

## Update of VRB Projects in China

亚化咨询 Asiachem Consulting

2026.6.23

\*本报告仅用于学习交流参考，不构成任何投资建议。

This report is for reference only and does not constitute any investment advice.

# Current Background



市场需求：可再生能源配套、交通电气化、AI基础设施

Market Demand: Renewable energy integration, Transportation electrification, AI infrastructure



需求侧对供电可靠性提出极致要求

Extreme reliability demanded by AI/data centers – outpacing traditional supply



新能源消纳亟需“缓冲垫”与“稳定器”

LDES: The Buffer & Stabilizer for Renewable Integration, PV(solar) & Wind Power generation)

政策环境：国家战略支撑

Policy: National Strategic Support

《新型储能规模化建设专项行动方案》



<Special Action Plan for the Large-Scale Development of New Energy Storage>  
2027 Target: 180GW+ Total Storage, ≥30% from >4h LDES



《关于完善发电侧容量电价机制的通知》  
<Notice on Improving the Capacity Tariff Mechanism on the Generation Side>

# 中国光伏与风电装机量预测 - Sinopec

## China's PV and Wind Power installation

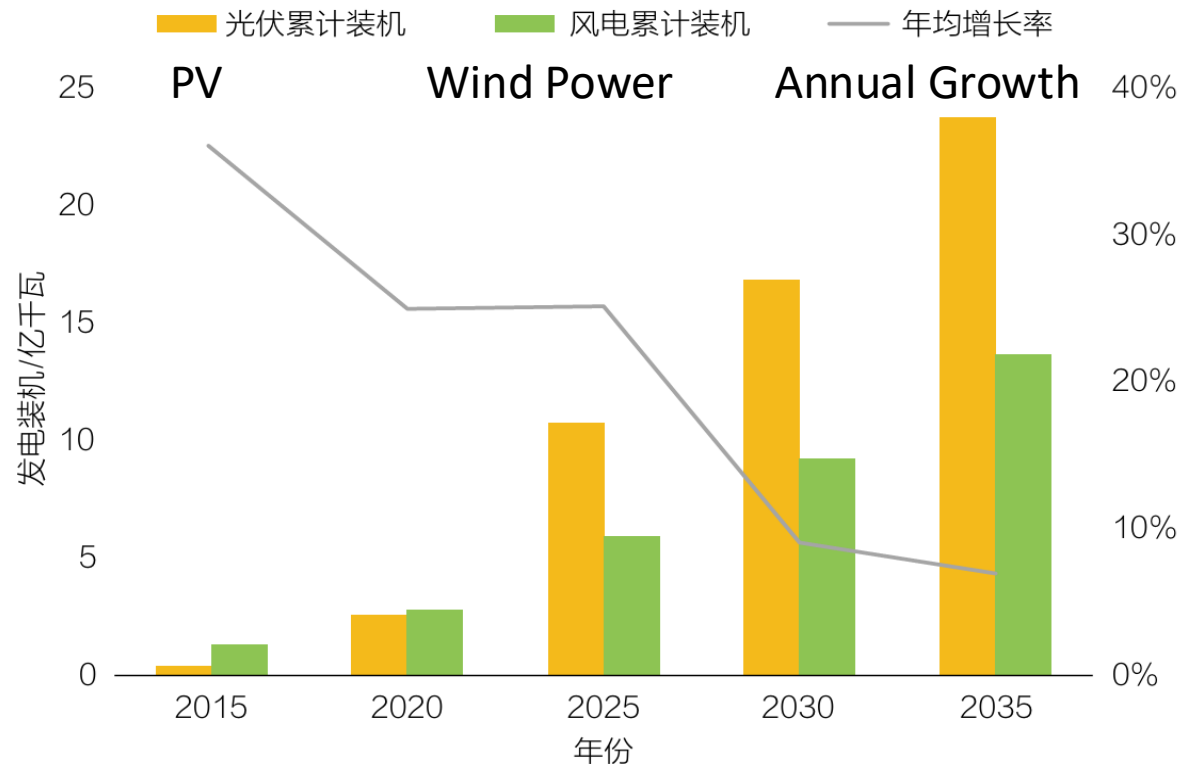

	2015	2020	2025	2030	2035
光伏装机	0.4	2.5	10.8	16.8	23.8
风电装机	1.3	2.8	5.9	9.3	13.6
年均增长率	36%	25%	25%	9%	7%

- 中国政府的目标是2030年碳达峰，2060年碳中和。需要可再生能源的持续发展。
- 中国可再生能源的装机量的持续增长，将驱动储能的需求增长。
- The Chinese government aims to peak carbon emissions by 2030 and achieve carbon neutrality by 2060, a goal that requires the continued development of renewable energy.
- The sustained growth of China's installed renewable energy capacity—driven primarily by solar (PV) and wind power—will fuel a continued rise in the demand for energy storage.

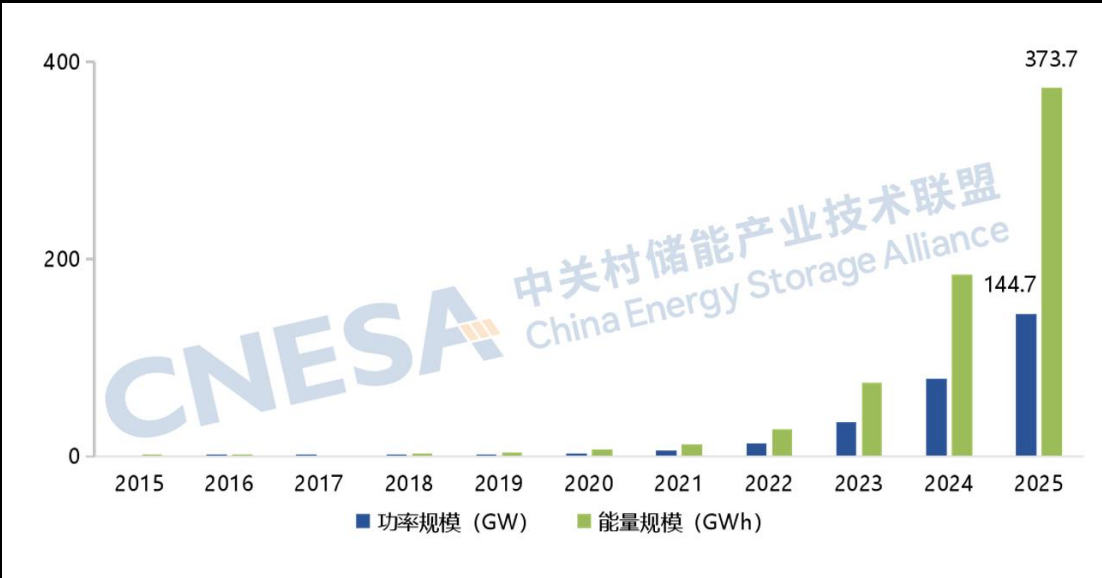

China New Energy Storage: Cumulative Installed Capacity

截至2025年12月底，中国新型储能累计装机规模达到**144.7GW**，同比+85%。2025年中国新型储能新增投运**66.43GW/189.48GWh**。

从技术路线看，锂离子电池仍然占据主导地位，但随着多个百兆瓦级长时储能项目的相继投运，技术结构正逐步呈现多元化趋势。全钒液流电池在液流电池的细分领域占主导地位。

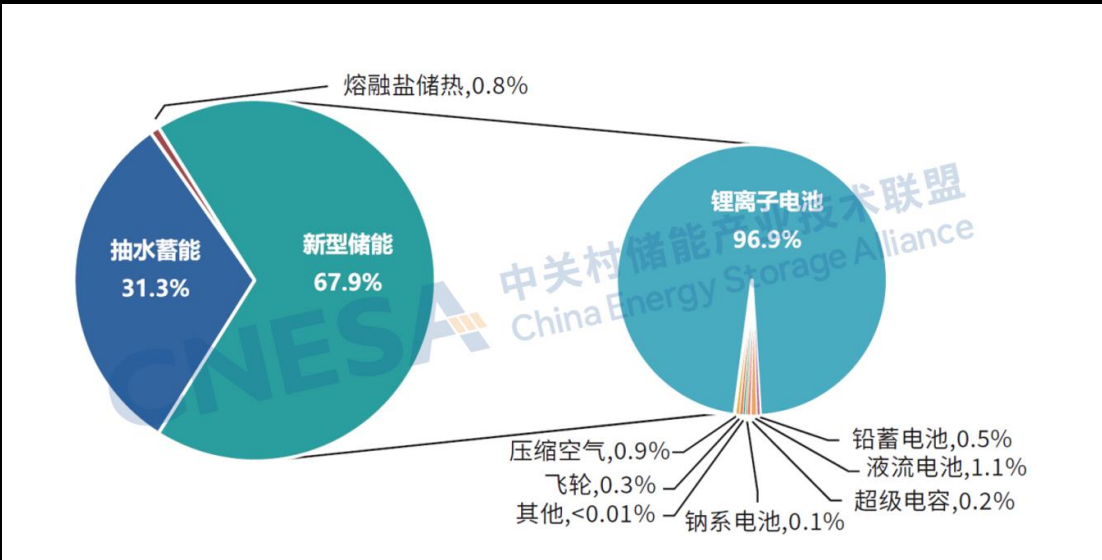

China Power Storage: Cumulative Installed Capacity (MW%)

- 2025 China New Storage: **144.7GW (+85% YoY)**
- New Additions **66.43GW/189.48GWh**
- LDES Projects Drive Tech Diversification
- Lithium-ion Dominates the total energy storage market
- **VRB dominates the niche market - liquid flow batteries**



**Why VRB is unique?**

**钒电池的独特性**

# SWOT: LIB vs VRB (VRFB)



	Lithium-ion Battery	Vanadium Redox Flow Battery
Strengths	<ul style="list-style-type: none"> <li>• High energy density, fast response</li> <li>• Mature supply chain in China</li> <li>• Economies of scale effect, <b>lower cost than VRB</b></li> <li>• Wide range of applications</li> </ul>	<ul style="list-style-type: none"> <li>• <b>Inherently safe</b>, no fire/explosion risk</li> <li>• Cycle life &gt;20 years</li> <li>• ideal for long-duration energy storage</li> </ul>
Weaknesses	<ul style="list-style-type: none"> <li>• <b>Fire risk - thermal runaway</b></li> <li>• Limited cycle life, faster degradation in long-duration use</li> </ul>	<ul style="list-style-type: none"> <li>• <b>High upfront costs (raw material costs + capex)</b></li> <li>• Energy density lower than LIB</li> </ul>
Opportunities	<ul style="list-style-type: none"> <li>• Market demand &amp; Policy support</li> <li>• Next-gen battery tech improves safety</li> <li>• Better recycling reduces environmental pressure</li> </ul>	<ul style="list-style-type: none"> <li>• Market demand &amp; Policy support</li> <li>• Growing LDES demand</li> <li>• Electrolyte leasing cuts cost</li> </ul>
Threats	<ul style="list-style-type: none"> <li>• Lithium price volatility</li> <li>• Competition from other LDES technologies</li> </ul>	<ul style="list-style-type: none"> <li>• Vanadium price volatility</li> <li>• The manufacture and supply chain is not mature enough</li> </ul>

# 全钒液流电池 All-Vanadium Redox Flow Batteries

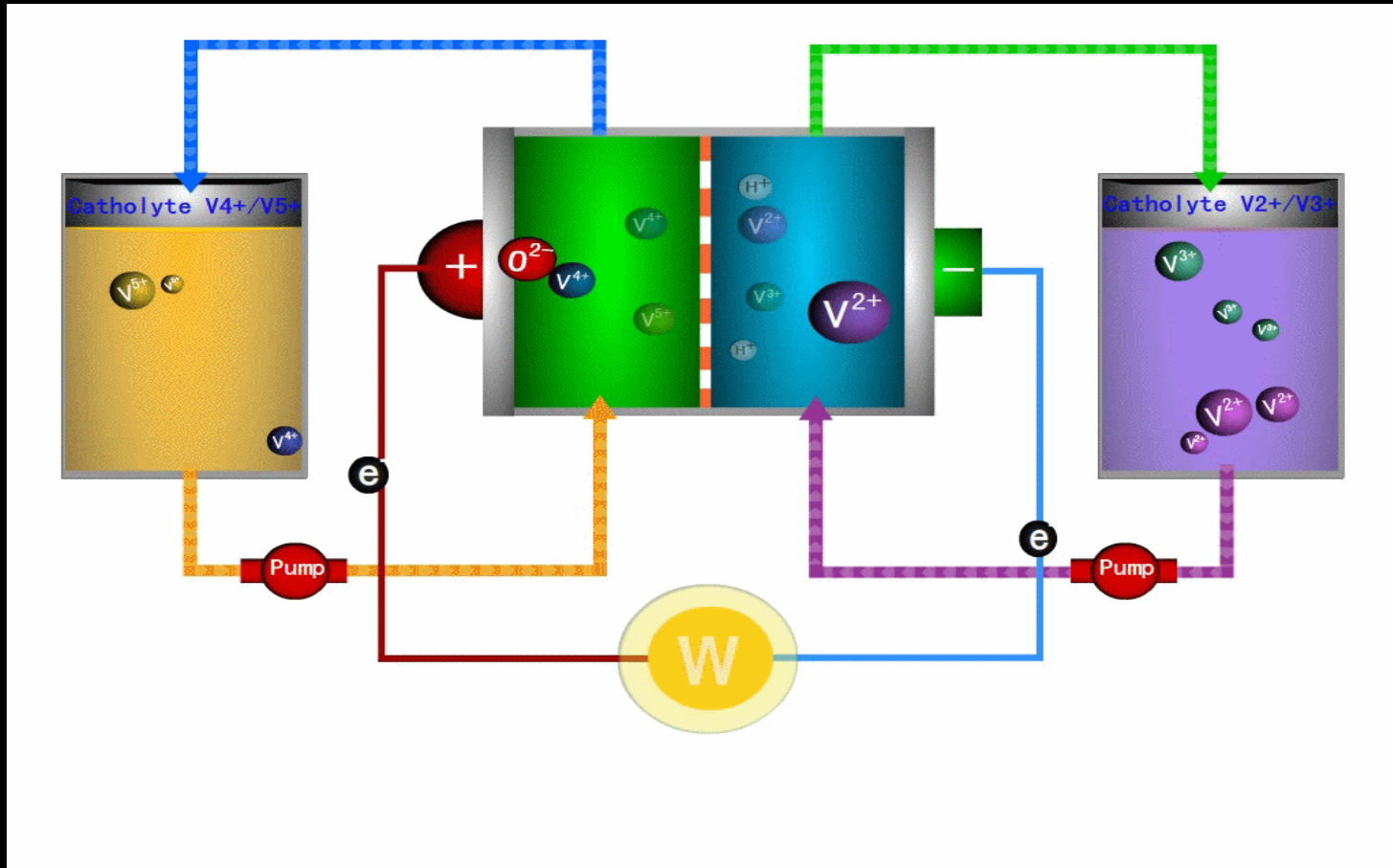

- 钒离子有2、3、4、5四种价态，有利用钒离子价态变化，实现电能储存和释放。
- Vanadium ions exist in four oxidation states: +2, +3, +4, and +5, and the changes between these states can be utilized to store and release the electrical power.

# 全钒液流电池的必要性

## The Necessity of All-Vanadium Redox Flow Batteries

适合于长时储能用液流电池的必要条件：

- 正负极电解液具有相同组分的双液流电池。
- 电解液活性组分对称、双液流！

The prerequisite for flow batteries in long-duration energy storage (LDES) applications:

- Dual-flow systems utilizing identical compositions for both catholyte and anolyte!
- Symmetrical active species in the electrolytes, dual-flow!



Professor Zhang Huamin  
Dalian Institute of Chemical  
Physics (DICP), Chinese  
Academy of Science.

# VRB Installed Capacity in China

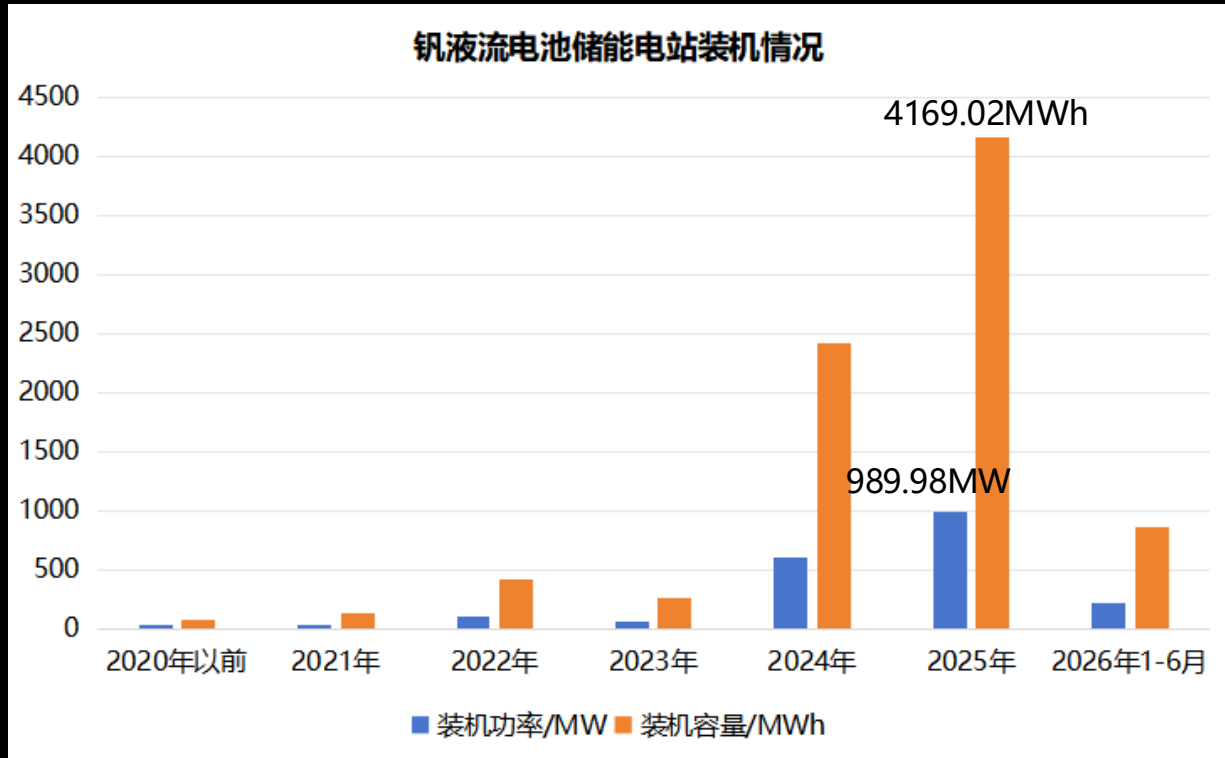

VRB Plant Installed Capacity

- 据亚化咨询不完全统计，截至2026年6月，全国建成投运的全钒液流电池储能项目超90个，装机规模达2037.18MW/8328.46MWh
- 2025年新增并网装机的全钒液流电池储能项目达989.98MW/4169.02MWh。
- 2023 pilot demo → Market Booming in 2024 → 2025 scaling-up kickoff
- Commissioned VRB projects >90;
- capacity 2037.18MW/8328.46MWh (as of Jun 2026)
- New VRB capacity in 2025: 989.98MW / 4169.02MWh

# Major VRB Companies in China



融科储能  
Rongke Power (RKP)



液流储能科技  
Enerflow



上海电气储能  
Shanghai Electric



寰泰储能  
Wontai



伟力得  
V-Liquid Energy



银峰新能源  
Yinfeng New Energy



星辰新能  
Star New Energy (SNE)



大力储能  
Big Power



北京普能  
VRB Energy



国润储能  
Green Energy



新新钒钛  
Xinxin V&Ti VFB



川发兴能  
SD V-Energy

# New Installed VRB Capacity in China (2025)

2025年新增并网装机的全钒液流电池储能项目

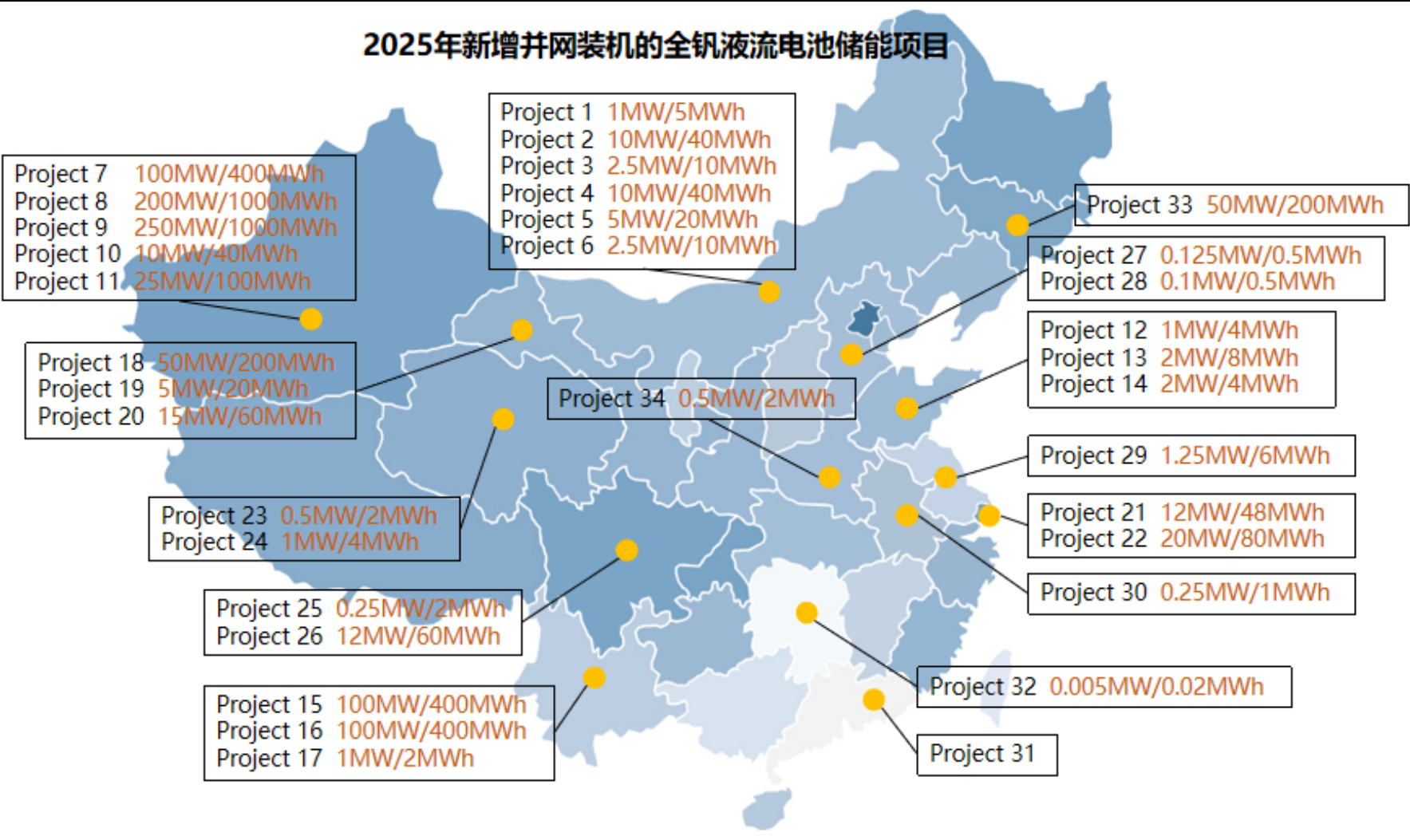

2025年新增并网装机的全钒液流电池储能项目

地点	项目名称	功率 /MW	容量 /MWh
内蒙古	内蒙古能源集团磴口县40万千瓦/160万千瓦时独立储能项目	1	5
	星辰新能、星钒瑞宇察右后旗20万千瓦/80万千瓦时独立储能电站项目成功并网送电（1万千瓦/4万千瓦时全钒液流电站项目（2.5MW/10MWh全钒液流电池储能系统）	10	40
	鄂尔多斯谷山梁星辰科创30万千瓦/120万千瓦时独立储能电站项目（2.5MW/10MWh全钒液流电池储能系统）	2.5	10
	内蒙古星钒涛钰25万千瓦/100万千瓦时独立储能电站（10MW/40MWh全钒液流电池储能系统）	10	40
	鄂尔多斯市国投集团新能源公司100万千瓦防沙治沙和风电光伏一体化工程（配置5MW/20MWh全钒液流）	5	20
	包头百灵10万千瓦/40万千瓦时电网侧储能电站（2.5MW/10MWh全钒液流电池储能系统）	2.5	10
新疆	哈密能源集团10万千瓦/40万千瓦时全钒液流储能项目	100	400
	三峡集团新疆吉木萨尔20万千瓦/100万千瓦时全钒液流储能一体化项目	200	1000
	新疆阿克苏乌什储能电站250MW/1000MWh全钒液流电池	250	1000
	新疆甘泉堡400MW/1600MWh（一期工程200MW/800MWh）混合电化学共享储能项目	10	40
	新疆华电巴州混合储能+100万千瓦风电一体化项目（25MW/100MWh全钒液流储能系统）	25	100
山东	滨河区诸城滨河200MW/400MWh电化学储能项目（1MW/4MWh全钒液流电池储能系统）	1	4
	国家能源集团山东公司蓬莱电厂101MW/205MWh复合储能电站（2MW/8MWh全钒液流储能系统）	2	8
	山东台儿庄台庄200MW/400MWh电网侧储能项目（2套100MW/200MWh全钒液流电池储能系统）	2	4

China Flow Battery Storage Project Database

Source: China VRB Industry Annual Report 2026

# New Grid-Connected VRB Energy Storage Projects (2025)

## 2025年新增并网装机的全钒液流电池储能项目



Region	Project Name	Power /MW	Capacity /MWh
Inner Mongolia	Inner Mongolia Baotou 400MW/1600MWh All-Vanadium Flow Battery Energy Storage Project (Phase I, 100MW/400MWh)	10	40
	Ulanqab Fengzhen Phase II 200MW/800MWh All-Vanadium Flow Battery Energy Storage Power Station Project (1st Phase, 100MW/400MWh)	10	40
	Ordos Gushanliang 30MW/120MWh All-Vanadium Flow Battery Energy Storage Project (2.5MW/10MWh All-Vanadium Flow Battery System)	2.5	10
	Inner Mongolia Wulatehou Banner 250,000 kW/1,000,000 kWh All-Vanadium Flow Battery Energy Storage Power Station	10	40
	Ordos Hangjin Banner 100MW/400MWh Independent Shared Energy Storage Project	5	20
	Ordos Dalad Banner 25MW/100MWh All-in-One Production, Storage and Application Integrated Project (2.5MW/10MWh All-Vanadium Flow Battery System)	2.5	10
	Hohhot Qingshuihe County 100MW/400MWh All-Vanadium Flow Battery Energy Storage Project	100	400
	Ordos City Hangjin Banner Future Zero-Carbon Park 2035 Phase I Project (100MW/400MWh All-Vanadium Flow Battery - Vanadium Mining - All-Vanadium Flow Battery Integration Project)	200	1000
	Xilingol League West Ujimqin Banner 250MW/1000MWh All-Vanadium Flow Battery Energy Storage Project	250	1000
Xinjiang	Xinjiang Aksu 400MW/1600MWh All-Vanadium Flow Battery Energy Storage Project (1st Phase, 200MW/800MWh, All-Vanadium Flow Battery + Green Hydrogen/Ammonia Integration System)	10	40
	Xinjiang Aksu 100MW/400MWh All-in-One Production, Storage and Application Integrated Project (2.5MW/10MWh All-Vanadium Flow Battery System)	25	100
	Hetian Yutian County 200MW/400MWh Vanadium-Titanium-Iron-Chromium Flow Battery Energy Storage Project (1MW/4MWh All-Vanadium Flow Battery System)	1	4
Shandong	Yantai Fushan District 101MW/205MWh All-Vanadium Flow Battery Energy Storage Power Station (2MW/8MWh All-Vanadium Flow Battery System)	2	8
	Shandong Linyi 200MW/400MWh Vanadium Battery Energy Storage Project (2MW/8MWh All-Vanadium Flow Battery System)	2	4
	Yantai Yixian 300MW/1200MWh All-Vanadium Flow Battery Energy Storage Project (Phase I, 100MW/400MWh)	100	400
Yunnan	Yunnan Puer 100MW/400MWh All-Vanadium Flow Battery Energy Storage Project	100	400
	Yunnan Dali 100MW/200MWh All-Vanadium Flow Battery Energy Storage Project (1MW/2MWh All-Vanadium Flow Battery System)	1	2
Gansu	Gansu Jiuquan 100MW/200MWh All-Vanadium Flow Battery Energy Storage Project (Phase I, 5MW/20MWh All-Vanadium Flow Battery System)	50	200
	Gansu Zhangye 105MW/420MWh All-Vanadium Flow Battery Energy Storage Project (Phase I, 5MW/20MWh All-Vanadium Flow Battery System)	5	20
	Longnan Wudu County 100MW/420MWh All-Vanadium Flow Battery Energy Storage Project	15	60
Shanghai	State Power Investment Corporation Shanghai Electric Power 12MW/48MWh All-Vanadium Flow Battery Energy Storage Project	12	48
	Fengxian District Multi-Energy Complementary Zero-Carbon Park Project (20MW/80MWh All-Vanadium Flow Battery + Hydrogen Production, Storage and Integrated Demonstration Project)	20	80
Qinghai	Qinghai Guoluo 100MW/200MWh All-Vanadium Flow Battery Energy Storage Project (Phase I, 0.5MW/2MWh All-Vanadium Flow Battery System)	0.5	2
	Qinghai Haidong 100MW/200MWh All-Vanadium Flow Battery Energy Storage Project (Phase I, 1MW/4MWh All-Vanadium Flow Battery System)	1	4
Sichuan	Sichuan Leshan 100MW/500MWh All-Vanadium Flow Battery Energy Storage Project (Phase I, 12MW/60MWh)	12	60
	Sichuan Dazhou 125kW/500kWh All-Vanadium Flow Battery System Demonstration Project	0.125	0.5
Hebei	Hebei Zhangjiakou 100kW/500kWh Commercial All-Vanadium Flow Battery Demonstration Project	0.1	0.5
Jiangsu	Suzhou SinoVess-250CS All-Vanadium Flow Battery Energy Storage Demonstration Project	1.25	6
Anhui	Anhui Huaibei 5kW/20kWh All-Vanadium Flow Battery Energy Storage Demonstration Project	0.25	1
Guangdong	Shenzhen Pinghu 5kW/20kWh All-Vanadium Flow Battery Energy Storage Test and Demonstration Project	0.005	0.02
Jilin	Jilin Changchun 100MW/600MWh All-Vanadium Flow Battery Shared Energy Storage Project (Phase I, 50MW/200MWh)	50	200
Henan	Henan Anyang 2.5MW/8.359MWh Vanadium Battery + 0.5MW/2MWh All-Vanadium Flow Battery Hybrid Energy Demonstration Project	0.5	2
<b>Total</b>		<b>989.98</b>	<b>4169.02</b>

Source:  
**ASIACHEM**  
 <China Flow  
 Battery Storage  
 Project  
 Database>

<China VRB  
 Industry Annual  
 Report 2026>

# Key VFB Energy Storage Projects (2025-2026)



## China Three Gorges Group Jimsar 200MW/1000MWh VFB Energy Storage Power Station, Xinjiang

China's largest and the world's  
first GWh-level VFB energy  
storage power station

三峡集团新疆200MW/1000MWh  
全钒液流储能电站——我国最大、全球  
首个单体GWh级全钒液流电站



## Ordos Gushanliang 300MW/1200MWh Independent Energy Storage Power Station

World's largest single-capacity  
grid-forming hybrid energy  
storage station

鄂尔多斯谷山梁300MW/1200MWh  
独立储能电站——全球单体容量最大的  
构网型混合储能电站，创新钒锂结合技  
术路线



## Yunnan Yongren 300MW/1200MWh VFB Energy Storage Project

China's largest VFB energy  
storage project

云南永仁300MW/1200MWh  
全钒液流储能项目——全国规模最大全  
钒液流储能项目



## Jilin Baicheng 100MW/600MWh VFB Shared Energy Storage Power Station

An important industrialized  
practice in the field of new  
energy for cold regions

吉林白城100MW/600MWh全钒  
液流共享储能电站——寒冷地区新  
能源领域的重要产业化实践

# Domestic GWh-level VRB manufacturing project

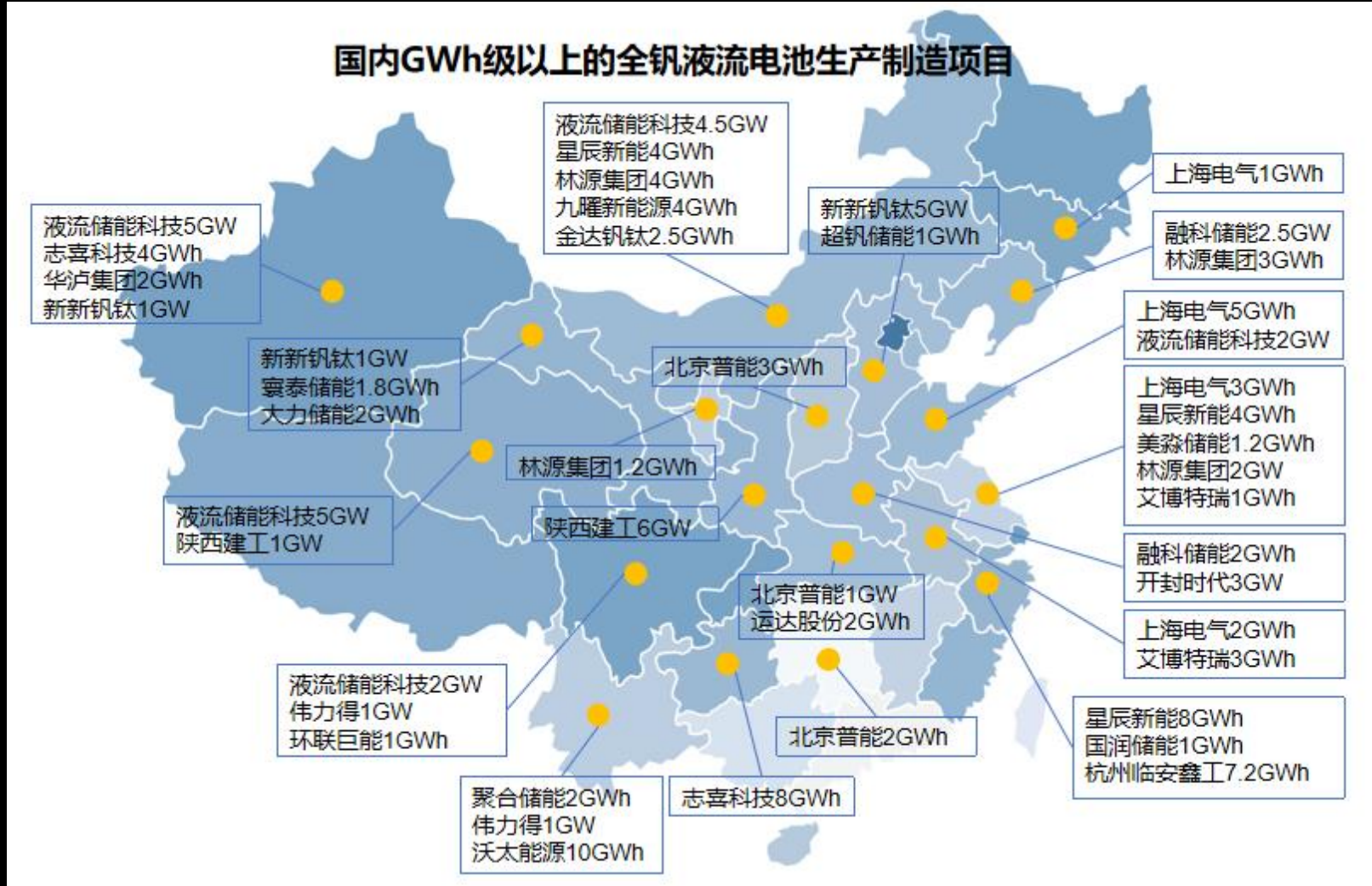

50+ GWh-scale VRB manufacturing projects in China

## Major Companies:

- 融科储能 RKP
- 液流储能科技 Enerflow
- 星辰新能 Star New Energy
- 上海电气 Shanghai Electric
- 伟力得 V-Liquid Energy
- 新新钒钛 Xinxin V&Ti VFB
- 北京普能 VRB Energy
- 寰泰储能 Wontai
- 大力储能 Big Power
- 国润储能 Green Energy

# Major VRB Electrolyte Capacity in China 2025



- 2025年产能35万立方
- 报道总产能510万立方
- 规划产能达100万立方
- 2026年预计投产60万立方
- 2025 capacity: 350 k m<sup>3</sup>
- Total reported: 5.1M m<sup>3</sup>
- Planned: 1M m<sup>3</sup>
- 2026 commissioning: 600k m<sup>3</sup>

# 全钒液流系统成本迭代：0.7元未来可期

Vanadium Redox Flow System Cost Roadmap: 0.7 RMB Targetable in Future

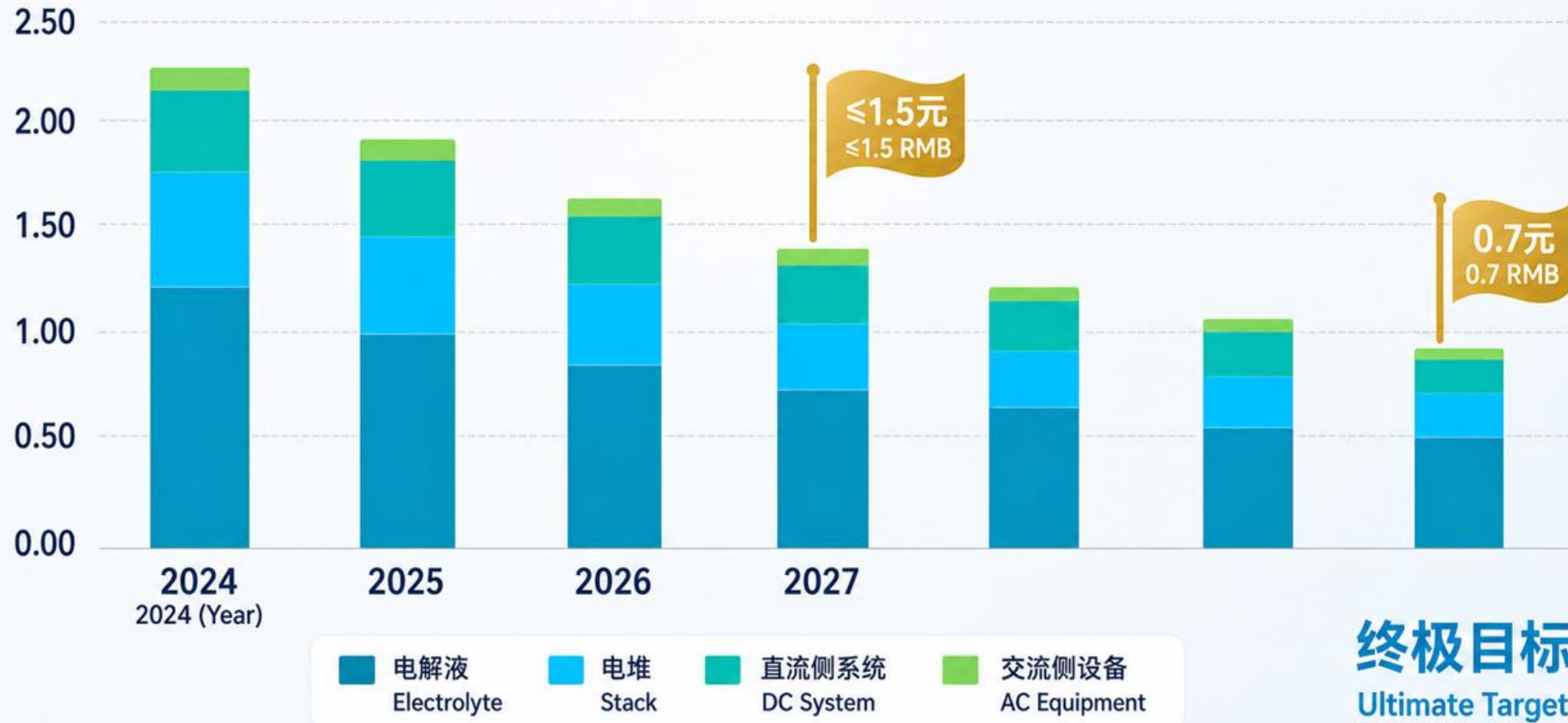

# Tech Advances: Localization & Cost

## ➤ Cost Decrease

System price: 4h < 2¥/Wh; 2025 EPC avg 2.39 (min 1.958)

Electrolyte: key material at 0.9¥/Wh – lower upfront cost

Cost roadmap: 1.5 ¥/Wh (2027) → 1.0 ¥/Wh (2030) → 0.7 ¥/Wh (target by ENERFLOW)

## ➤ Core Stack Breakthrough

Jun 2026: ENERFLOW launched a 200kW VRB stack (world's largest) with 220mA/cm<sup>2</sup>, 83% efficiency-industry-leading.

## ➤ Standards Progress

May 2026: Two IEC VRB standards approved – proposed by RKP & DICP

IEC 63686: Stack requirements & test methods

IEC 62932-4-2: Electrolyte test methods



# Market Growth: Demand booming

- 2025年钒液流电池储能项目新增装机近1GW/4.2GWh，估算市场规模约90–113亿元人民币
- 预计2026年钒电池新增装机达1.5GW，预计2030年钒电池新增装机将达10GW，2025-2030年CAGR为60.4%。
- 2025: ~1 GW/4.2 GWh new VRB, estimated market 9.0–11.3B CNY → scaling kickoff
- 2026E: > 14B CNY (project deliveries ramp up, optimistic)
- 2030E: ~50B CNY market (optimistic)
- **VRB New Capacity Forecast:** 2026E new capacity: 1.5 GW; 2030E (optimistic): ~ 10 GW; CAGR (2025–2030): 60%

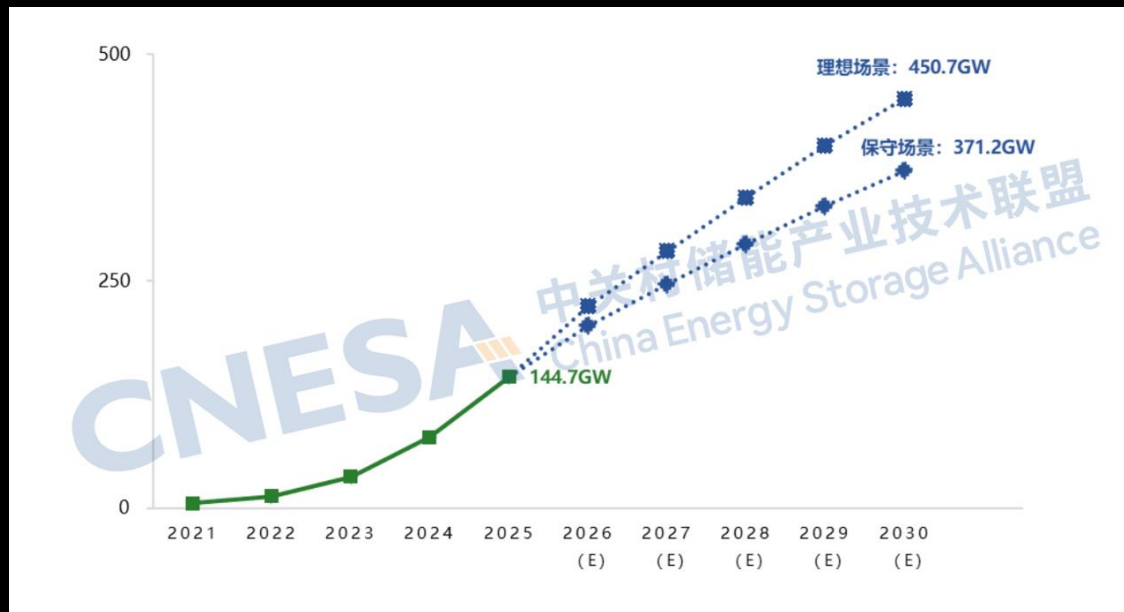

China New Storage Capacity Forecast

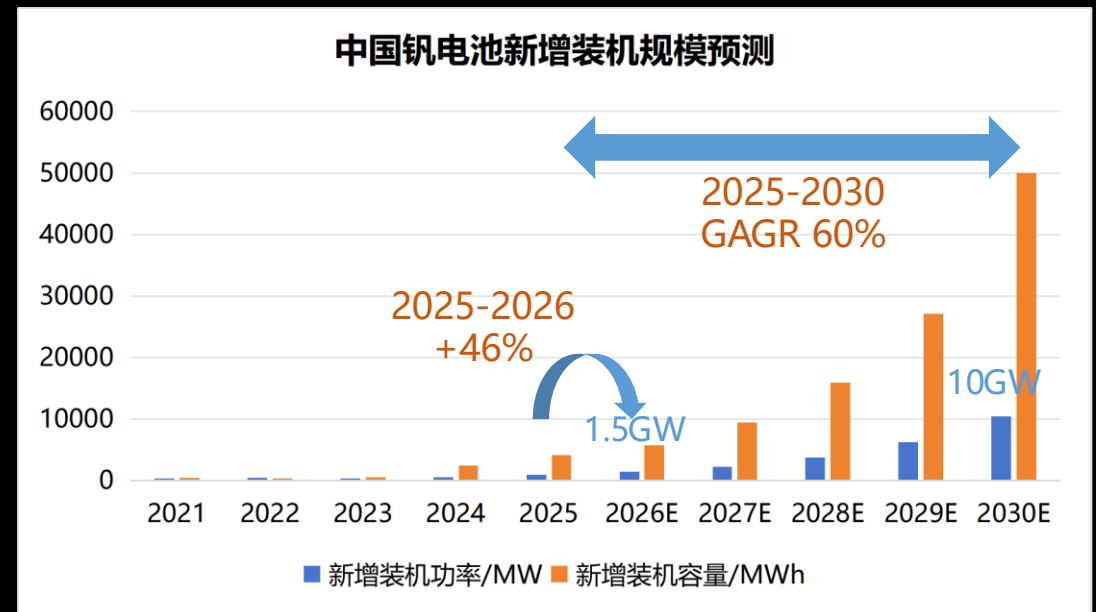

China VRB New Capacity Forecast

# VRB Global Expansion

## 01 Product Exports

- Sell stacks, electrolytes, and systems
- Leverage mature products for rapid international market entry

### ENERFLOW × EORA Energy



Project will partially replace diesel gensets with ENERFLOW-200

## 02 Tech & EPC

- design/manufacturing tech transfer
- EPC/service for large projects

### RKP × Richmond Vanadium Technology



"Mine-to-Battery" pact-jointly develop VRB & LDES projects in Australia

# Energy storage drives V consumption

Theoretical Demand: **1 kWh electricity storage needs 5.6 kg V<sub>2</sub>O<sub>5</sub>**

- In China: Vanadium consumption hit 25,200 t in 2025 (V<sub>2</sub>O<sub>5</sub>) for energy storage use, ranking No.2, accounting for about 20% total Vanadium consumption
- Following the No.1 consumption (steel 70.9%)
- 2026 forecast: Energy storage V demand ~32,000 t
- 2030 outlook: Energy storage V demand ~90,000 t

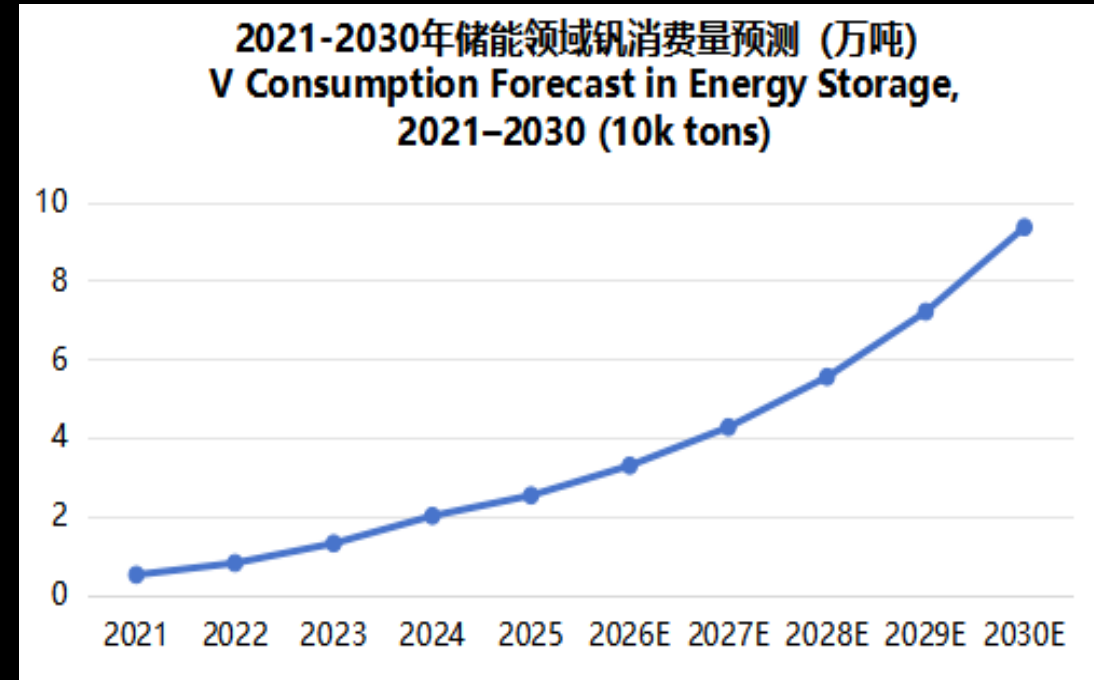

# Summary & Outlook

- Market demand and policy support have jointly driven the growth of China's energy storage market, particularly in sectors such as solar and wind grid integration, transportation electrification, and AI infrastructure.
- Lithium-ion batteries dominate the overall energy storage market, while vanadium redox flow batteries (VRBs) hold the leading position within the flow battery segment.
- Although VRBs offer safety advantages, high costs remain their most significant challenge.
- Some Chinese companies are actively working to reduce costs, targeting a progression from 1.5 CNY/Wh in 2027 to 1.0 CNY/Wh in 2030, with an ultimate goal of 0.7 CNY/Wh.
- Achieving cost breakthroughs is critical to making long-duration energy storage (LDES) cost-competitive with grid power.
- International cooperation in technology and markets is essential; it facilitates technological breakthroughs and practical deployment, lowers costs, enhances competitiveness, strengthens collaboration on vanadium resources, and expands the global energy storage market.

# China VRB Industry Annual Report 2026



## English – Chinese Edition

- VRB Industry Overview
- Industry Policies
- Market Size & Forecast
- Vanadium Resources Analysis
- Electrolyte Supply & Demand
- Current Capacity & Pipeline
- VRB Stack Core Materials

Contact : [yaoxy@chemweekly.com](mailto:yaoxy@chemweekly.com)

### 2026 中国全钒液流电池产业 年度报告

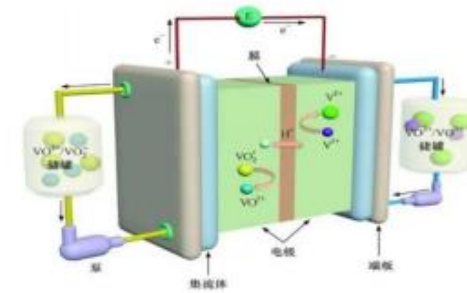

版权所有 © 2026 亚化咨询

免责声明：

本报告仅供授权读者使用。未经亚化咨询公司书面许可，订阅者不得转让、出售、对外发表该本报告的内容（包括但不限于其中的部分图片、表格和文字信息）。

本报告基于公开信息和亚化咨询的专有知识，不涉及任何企业机密信息。报告力求信息数据的可靠性，但不完全保证其准确性及完整性。订阅者做出的商业决策与亚化咨询无关。

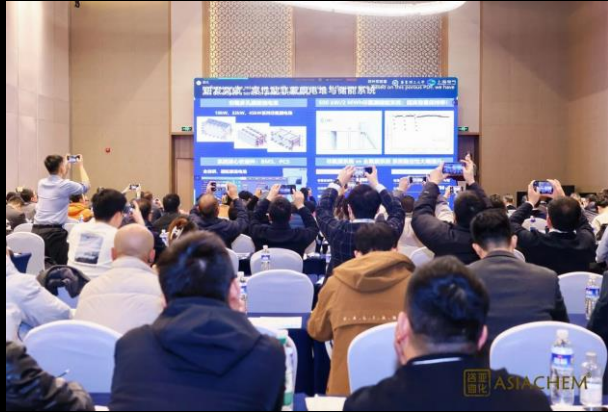

# 中国国际钒液流电池论坛2025

China International Vanadium Flow Battery Forum

## —技术进步与降本之路

-The way of Tech Progress & Cost Reduction

12.11-12 合肥 Hefei

联合主办  
Co-Organizer



支持  
Supporter

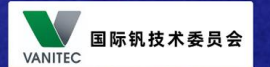

第三届钒原料、电解液与钒电池储能论坛组织参观西安隆基绿能

中钠储能欢迎亚化钒电池储能论坛考察团参访



# 中国国际钒液流电池论坛2026

China International Vanadium Flow Battery Forum

—**技术进步与降本之路**

—The way of Tech Progress & Cost Reduction

**时间地点：待确认**

Time and location: To be confirmed

**We welcome speakers, please contact : [yaoxy@chemweekly.com](mailto:yaoxy@chemweekly.com)**



# 中国钒液流电池项目发展

Update of VRB Projects in China

**Thanks for your attention !**